

HT-BCT05A55V/84V Lithium Battery Pack Parameter Tester

This tester is suitable for testing various parameter of power supply, such as different kinds of rechargeable battery, removable power and digital adapter. The parameter is for judging the quality and performance of mobile phone and laptop notebook and other digital product.

Manual Instruction



Thank you for choosing  series product. These products are designed to make your work more convenient, safe and efficient. such that you might become familiar with all the operations of the tester, an instruction manual has been included. Please read before operation.

Please store this manual in a safe location for both current and future reference.

Website: <https://www.heltec-energy.com/>

E-mail: echo@heltec-bms.com

Tel: 18123313360

Address: 64th ChengHong road, chenghua Section,
Chengdu ,SiChuan ,China

1、 Summarization

HT-BCTO5A55V/84V multifunction parameter of intelligent comprehensive tester is controlled by microchip. There are a low power computing chip from united state and a microchip from Taiwan. Testing various parameter of battery is precisely. There are dual rows of 4 digits to display parameter of voltage, current, resistance, capacity precisely. The testing result is more powerful and more precisely. The tester is suitable for testing voltage, resistance, capacity and discharging current of single cell battery and battery pack.

Description of key

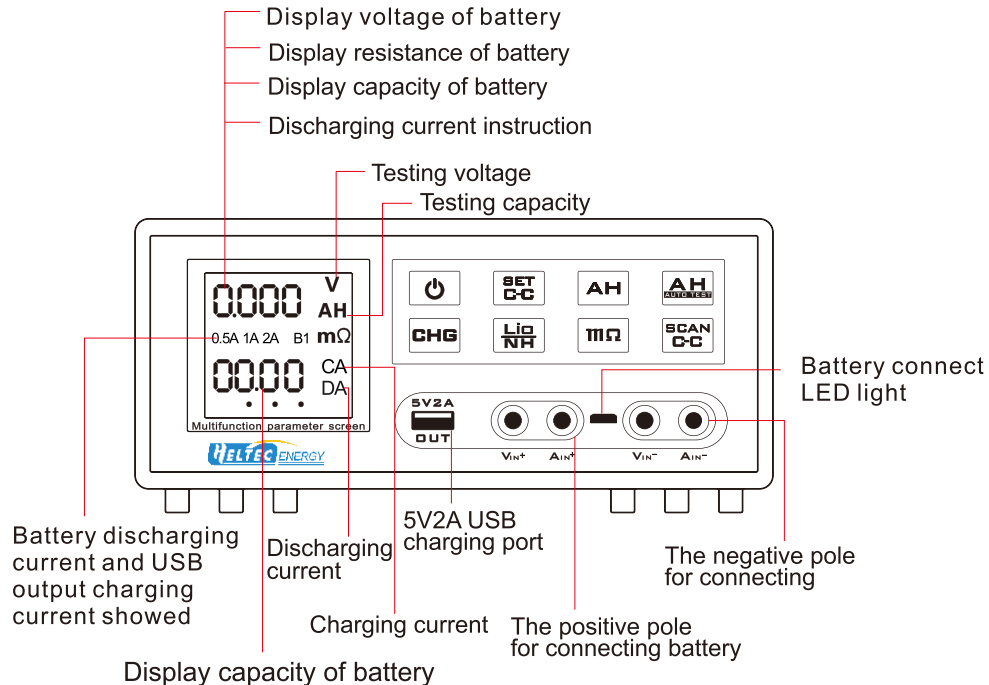
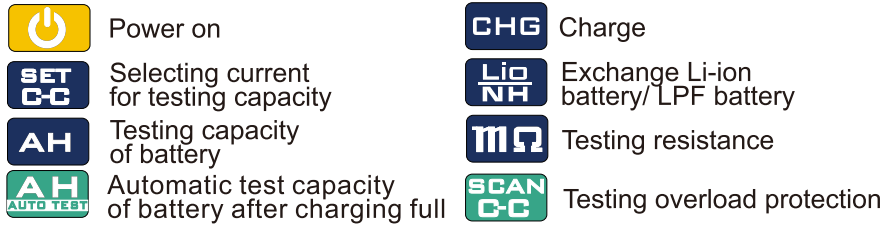

SAFETY INSTRUCTIONS



- All contents of this product are related to safety. Users must abide by them. Failure to operate in accordance with the instructions may be dangerous.
 - The safety warning in this item are mainly for the correct use of this product. The precautions explain the danger, the degree of harm, and the possible matters. Illegal operation may damage your goods, property, and even endanger your personal safety.
1. Before using the tester, please read this manual carefully and keep it properly for future use.
 2. Do not use other accessories without the permission of the manufacturer, do not modify, and do not disassemble and repair them by non-professional maintenance personnel, otherwise fire, electric shock and injury accidents may occur.
 3. Please check whether the product is damaged after unpacking, check whether the accessories are safe, and pay attention to check that the plug and power cord must be intact to avoid the risk of electric shock.
 4. Please keep this product out of the reach of children or incapacitated persons. Children and incapacitated persons should use this product under the supervision of a guardian.
 5. In the event of a malfunction, remove the power plug immediately and do not leave the defective product in working order.
 6. Before use: Make sure your power source is adequate for the product voltage rating. The voltage rating is on the product label. The product users either 100-127Vac or 220-240Vac and 50/60 HZ. Connect the power cord between the product and a grounded AC outlet.
 7. Must be use single-phase fixed three-stage socket with reliable grounding. It is strictly prohibited to use flexible wire mobile socket and to share a socket with other electrical appliances.
 8. When not in use, the power supply should be cut off to ensure safety.
 9. Do not use this product in a water mist environment or in a flammable or explosive environment.
 10. Keep the power cord away from heat sources.

2、 Range of applications

- 1、 The tester is for manufacturers which produce lithium battery, nickel battery, battery packs, power bank. It is for R&D and quality control, operating stores for purchase quality testing and maintenance testing.
- 2、 It could select battery cell fast in charging and discharging test.
- 3、 Test resistance fast to select cell for assembling battery pack.
- 4、 Aging test and thermal stability test.
- 5、 Testing charging current of mobile phone and notebook for maintenance.

3、 The application use of product

Prompt: Please note that test the corresponding current voltage drop of data wire first when tester is testing digital power supply or mobile phone adapter charger with current load capacity. Because the measured voltage value is the voltage value which pass through data wire. The tested value is lower than the actual value. It is caused by the resistance of data wire to drop the voltage down.

4、 What is function of each pressing key?

Testing voltage



4.125 V
1A B2
0000

Turn on the tester. Distinguish the positive pole and negative pole. The testing clip and fixture connect to the corresponding pole. Please confirm the tested battery whether is in the range of testing. The tester sound "Di Di. The monitor displays the current voltage of battery. As the picture shows the voltage is 4.125V. Please note that connect negative pole first and connect positive pole later before testing. Please disconnect the positive pole first and disconnect the negative pole later when finish testing.

Testing mode selection



3.815 V
1A B2
0000

42.13 V
1A B1
0000

Press key to select tested battery's type. "B1" is for battery pack. The terminal discharging voltage is 7V. "B2" is for single cell battery. The terminal discharging voltage is 2.75V. In battery pack testing, Please select "B1" mode and protective board must be installed on battery pack. Otherwise, the battery pack will get damaged.

7、 What's the testing method of current capacity conversion efficiency and power conversion efficiency of mobile power

- 1) The measured total capacity of battery pack mah is A;
- 2) Connect the battery pack and the circuit board. and measure the output capacity of mobile power mAh as B..
- 3) Current capacity conversion efficiency of this power bank is $B \div A = \%$. For example, the capacity of mobile power is 4000mah. the output capacity of mobile power is 2600mah. the result is $2600 \div 4000 = 65\%$.
- 4) The power conversion efficiency of mobile power is $A \times 3.6V \div B \times 5V$,

$$\text{The situation of battery cell is } \frac{2600 \times 5V}{4000 \times 3.6V} = \frac{13000}{14400} = 90.27\%$$

8、 Packing list



Tester

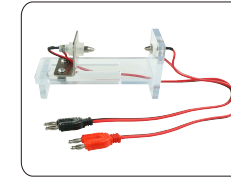

Testing fixture



Testing clip



USB data wire



Power cord

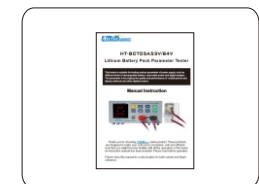

Manual instruction

9、 Attention to use

- 1、 There is certain heat will be produced in capacity testing because internal discharging. Please put the tester in the ventilation environment testing.
- 2、 Please do not press start key in testing process otherwise the testing result of before will be wiped.
- 3、 Please do not make phone call near the tester in testing. Prevent mobile phone radio frequency signal radiation from interfering with tester.
- 4、 Please do not reversed poles of battery when connect to tester. The tester will get damaged if the poles of battery is reversed to connect to tester.
- 5、 There will be high temperature on the surface of tester in discharging process. Please do not touch the tester in discharging process to avoid scald.
- 6、 The tester must be used in dry environment. The water mist environment will cause testing value not correctly.
- 7、 The resistance of battery is the actual direct current resistance value. It is the value of voltage variable in 1A discharging. The result of DC resistance is bigger than the result of AC resistance. But the result of DC resistance is more meaningful than the AC resistance.
- 8、 The extreme input voltage of tester is 55V/84V. Please do not test battery pack which is over than 55V/84V.
- 9、 The functions of charging and discharging (CA+DA) cannot not use together. Otherwise the testing current display is not precisely.

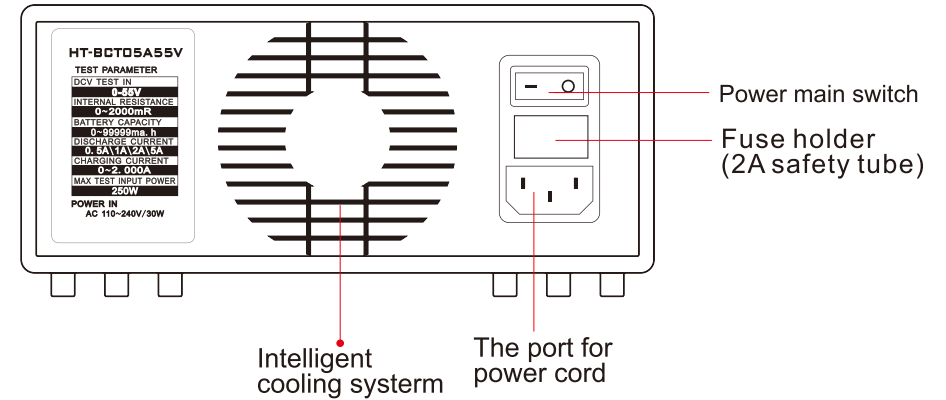

The unique features of tester

1. The first original design is tester which is with capacity measurement after charging automatically.
2. There is the charging current display function for movable power bank and mobile phone, note book.
3. There is microchip controlled precise monitor.
4. There are Ampere hour value for no-load and discharging voltage, charging and discharging current, resistance and capacity.
5. There are 0.5A/1A/2A/5A discharging current could be selected to test capacity of battery.
6. It is suitable for lithium / nickel battery, battery pack, sun-generated electric power.
7. There are icons and words for corresponding to the test function for display.
8. tester will alarm when the connection is wrong.



Please note that the “B1” mode is for discharging battery pack. “B2” mode is for the discharging 7V cut off voltage of single cell battery. The cut off voltage is 2.7V. The charging function is invalid when battery pack connect to the tester. The tester will distinguish battery pack automatically. **(The battery pack must connect with protective board in discharging.)**

Automatic charge

4.125^V
1A B2
0.045^{CA}

Turn on the tester. The tester will sound "Di Di" when the tested battery is in the right connection with tester. Press **CHG** key to charge battery. The indicator light of red will be on. The signal of voltage will be in flash. This is in charging. The tester will stop charging automatically when the battery is in full charge. Please note that charging is in constant voltage constant current mode. The charging current will be decreased as the voltage increase. Please pay patient to wait because charging time is long. This charging function is ineffectiveness when the tester connects to battery pack.

The key for testing capacity after charging

5012^{AH}
1A B2
0000^{DA}

Turn on the tester. The tester will sound "Di Di" when the tested battery is in the right connection with tester. Press **CHG** key to charge battery. Set charging in constant voltage constant current mode. The charging current will be decreased as the voltage increase. And press **AH** key which is for testing capacity after charging automatically. tester will charge battery full and discharge automatically for capacity testing. As the picture shows in the left is in the capacity testing. Please note that this function is only suitable for single cell battery not for battery pack.

5、 Testing range of parameter

Voltage of power supply	AC100~240V
Testing voltage	0~55V;0~84V
Testing resistance	0~2000mΩ
Testing capacity	0~9999ma · h
Product size	300x90x82mm
Testing discharging current	0. 5A/1A/2A/ 5A
Displaying discharging current	0-5A
External USB output	5V/2A

6、 Operation**Testing lithium battery pack**

1. The battery pack must connect with protective board to use. please connect with the negative pole of battery pack first. and then connect with the positive pole of battery pack later. the tester will sound "Di Di" if the connection is right. otherwise, the tester will alarm.



2. The decimal point of monitor display will move after the tester connects with battery pack. As the picture shows the voltage of battery pack is 41.28V. Press "AH" to select testing battery mode. The "B1" mode is for battery pack testing.



3. The monitor will display voltage of battery after the tester connects with battery pack. As the picture shows this batteries' voltage is 40.20V. That means the voltage of battery pack is normal.



4. The function of charging and discharging automatically after charging full is ineffectiveness. No response when press these key.



5. Discharging battery pack. please discharge current of battery pack in "B1" mode and select discharging current. Please note that the decimal point rearward 1 movement that means the discharging current increase ten times. Press "SET" key to select discharging current to 5A. NOTE: There will be high temperature on the surface of tester in discharging process. Please do not touch the tester in discharging process to avoid scald.



6. And the tester will be turn off automatically for protection when current is over than 5A. please select 5A to discharge. The value of capacity will be shown on monitor after discharging.

Testing single cell



1. First, connect battery. Please must connect the negative pole first and then to connect the positive pole later. The black is for the negative pole. The red is for the positive pole. Otherwise the tester or battery will be damaged by the current is too big.



2. The monitor displays "B2" mode after connect battery. "B2" mode is for testing single cell battery mode. Please press key to exchange to "B2" mode if the mode is not in "B2" mode. The single cell battery must in "B2" mode to test parameter..



3. Testing voltage of battery. The monitor display voltage of battery after connection well. As the picture shown the voltage of this battery is 3.182V. that means the voltage of battery is normal.



4. Testing resistance of battery. The tester need to be returned on. Press "mΩ" for testing resistance. Please note that the tested parameter more precisely when press testing resistance key two times. As the picture shows the battery is in the testing resistance.



5. Testing capacity of battery. Press "AH" for testing capacity of battery. The tested battery must be in full charge. The monitor will display the capacity of battery after discharging.



6. Testing capacity is automatically after battery is charging full. Press "CHG" key to charge and press "AH" key. The light is on. Discharging capacity is automatically when the battery is charging full.

Testing capacity



Turn on the tester. Confirm testing battery mode. "B1" is for battery pack testing. "B2" is for single cell battery testing. Press "Li/NH" to exchange mode. Press "AH" key to test capacity. Press "SET/C-C" key to select discharging current. There are 0.5A/1A/2A discharging current to be selected. Wait for 1-2 second after selecting discharging. The monitor displays the current discharging current. The monitor will display the capacity of single cell battery / battery pack after testing. Please note that the tested battery / battery pack must be in full charge before discharging testing. The result of testing capacity will be more precisely. Please note that the decimal point rearward 1 movement that means the discharging current increase ten times. There are 5A/10A/20A discharging current in battery pack mode. But battery pack will get damaged because the discharging current is too big. Please select 5A discharging current in battery pack testing. T-688 tester will turn off automatically for self-protection when discharging current is over than 5A.



Testing resistance



Turn on the T-688 tester. The tester will sound "Di Di" when the tested battery is in the right connection with tester. The voltage of battery / battery pack will be showed when press "mΩ" key. And show the signal of "√/√". The monitor displays the resistance of battery later. As the picture showed the resistance is 23mΩ. Please pay attention that the testing clip and fixture must connect with battery well. Otherwise, the tested result will be not correct.



Please note that is there any oxide on the surface of battery's positive pole or negative pole or not. Use dry sanding paper to wipe oxide off to show the metal surface of battery electric poles. Please also check the testing fixture and testing clip which are the complete set with tester whether are in good connection with tester and battery. Otherwise, the result of tested resistance will be too large or the result will be different in each test.